

SOCKETWELD FITTING - PIPE FITTINGS



INSTRUMENTATION

PIPE FITTINGS

PIPING SOLUTIONS

ADDITIONAL PRODUCTS



FORGED PIPE FITTINGS



Forged fittings are stocked to the dimensional specifications and in the material listed below. Where two specifications are quoted dimensions are common to both specifications

Elbow, Tees, Unions (3000 lb), Couplings, Half Couplings, Caps, Hex Plugs, Round Plug, Hex head bushings, Flush bushing, Hexagon Nipples, Swage Nipples, Round nipples, Reducing inserts, ball Plugs. Olets, Elbows, Laterolets and Nipolets.

As per : MSS SP 83/ MSS SP 99/ ASTM A 733 / MSS SP 79/ MSS SP 95/ Design to ANSI B 31.1 (1986)

Materials : ASTM A 105, A105N, A350 LF/LF2, A 182 F304/304L/F321/ F316/F316L, A182 F5/F9/F91/F11/F22 & As per upon request

Threading : Thread fittings are threaded to ANSI B1.20. 1 NPT

Test Certificates : Fittings test certificates to DIN 50049, 3.1.b are available and are supplied with all goods sold. test certificates include full chemical analysis with Carbon Equivalent.

Material conforms to NACE MR 175 (latest edition), has a maximum C.E. of 43% and a maximum carbon content of .23%

Marking: Plugs, Bushings, Hex nipples are marked with the manufacturers mark, heat code and material identification

Other fittings (excluding round nipples and swages) are marked with manufacturers mark, heat code, material identification, pressure rating and nominal size

Round Nipples and swage are marked with the manufacturers mark, heat code, material identification, schedule(s) or pressure rating and nominal size (s)



NOMINAL PIPE SIZES CONVERSION FROM INCHES TO MILLIMETRES

Nominal Bore Inches	Nominal Bore Millimetre
1/8"	6 mm
1/4"	8 mm
3/8"	10 mm
1/2"	15 mm
3/4"	20 mm
1"	25 mm
1-1/4"	32 mm
1-1/2"	40 mm
2"	50 mm
2-1/2"	65 mm
3"	80 mm
3-1/2"	90 mm
4"	100 mm
5"	125 mm
6"	150 mm

Correlation of fittings class with Schedule Number or Wall Designation of pipe for calculation of Rating

AMERICAN NATIONAL STANDARD FORGED STEEL FITTINGS SOCKET WELDING AND THREADED ANSI B 16.11

1. This table is intended to restrict the use of pipe of thinner or thicker wall with fittings. Pipe actually used may be thinner or thicker pipe is used is strength may govern the rating. When thicker pipe is used (e.g. For mechanical strength of the fitting governs the rating.

Pressure Class Designation of Fitting	Types of Fitting	Pipe (1) Used for Rating Basis	
		Schedule No.	Wall Designation
2000	Threaded	80	XS
3000	Threaded	160	-
6000	Threaded	-	XXS
3000	Socket-Welding	80	XS
6000	Socket-Welding	160	-
9000	Socket-Welding	-	XXS

SCREWED PIPE FITTINGS

(Straight & Reducing Hexagon Nipples)
(Dimensions in Millimetres)

Pressure Class 3000

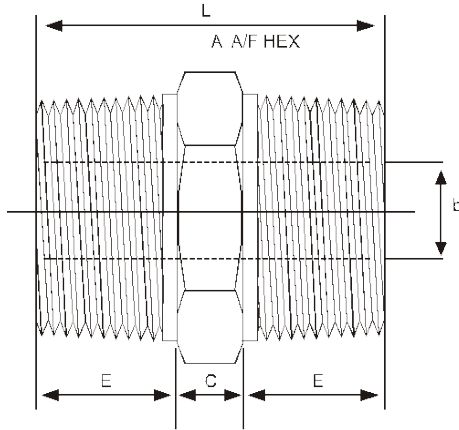

N.B	Dim.A (mm)	Dim.b (mm)	Dim.C (mm)	Dim.E (mm)	Dim.F (mm)	Dim.L (mm)
6	11	5	6	10	.	26
8	15	8	6	15	.	36
8x6	15	5	6	15	10	31
10	18	11	3	16	.	40
10x8	18	8	3	16	15	39
15	22	14	8	20	.	38
15x10	22	11	8	20	16	44
15x8	22	8	8	20	15	43
20	27	19	10	21	.	52
20x15	27	14	9	21	20	50
20x10	27	11	9	21	16	46
25	35	24	10	25	.	60
25x20	35	19	10	25	21	56
25x15	35	14	10	25	20	55
40	50	38	16	26	.	68
40x25	50	24	16	26	25	67
40x20	50	19	16	26	21	63
40x15	50	14	16	26	20	62
50	62	49	17	27	.	71
50x40	62	38	17	27	26	70
50x25	62	24	18	27	25	70
50x20	62	19	17	27	21	65
50x15	62	14	18	27	20	65

Pressure Class 6000

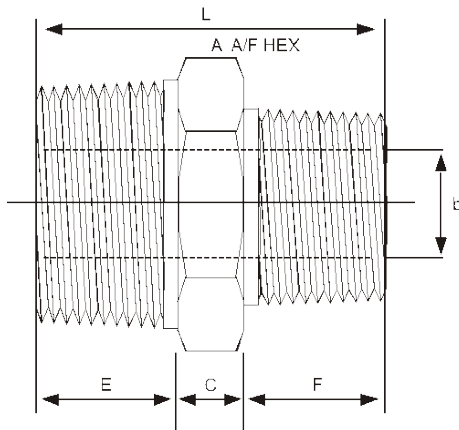

N.B	Dim.A (mm)	Dim.b (mm)	Dim.C (mm)	Dim.E (mm)	Dim.F (mm)	Dim.L (mm)
6	11	2	6	10	.	26
8	15	6	6	15	.	36
8x6	15	2	6	15	10	31
10	18	8	3	16	.	40
10x8	13	6	8	16	15	39
15	22	11	8	20	.	48
15x10	22	8	8	20	16	44
15x8	22	6	8	20	15	43
20	27	13	10	21	.	52
20x15	27	11	9	21	20	50
20x10	27	8	9	21	16	46
25	35	17	10	25	.	60
25x20	35	13	10	25	21	56
25x15	35	11	10	25	20	55
40	50	30	16	26	.	68
40x25	50	17	16	26	25	67
40x20	50	13	16	26	21	63
40x15	50	11	16	26	20	62
50	62	39	17	27	.	71
50x40	62	30	17	27	26	70
50x25	62	17	18	27	25	70
50x20	62	13	17	27	21	65
50x15	62	11	18	27	20	65

DIMENSION IN MM OF FORGED SCREWED FITTINGS TO ANSI B-16.1 THREADED TO ASA B 2.1

90° ELBOWS

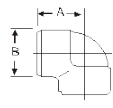

TEE

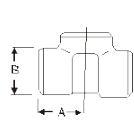

45° ELBOW

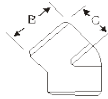

UNION

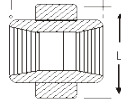

COUPLING

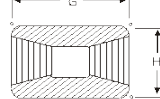

PIPE CAP

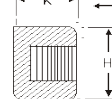

BUSHING

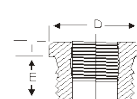

HEX HEAD PLUG

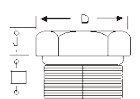

HALF COUPLING = G/2

NOM BORE	PIPE O.D.	3000 L.B.S.						COMMON FACTORS						6000 L.B.S					
		A	B	C	G	H	K	D	E	F	I	J	L	A	B	C	G	H	K
1/8"	10.3	21	22	17	32	16	19	11	10	40	-	6	-	25	25	19	32	22	-
1/4"	13.7	25	25	19	35	19	25	16	11	43	3	6	32	29	33	22	35	25	27
3/8"	17.2	29	33	22	38	22	25	17.5	13	48	4	8	38	33	38	25	38	32	27
1/2"	21.3	33	38	25	48	29	32	22	15	51	5	8	46	38	46	29	48	38	33
3/4"	25.7	38	46	29	51	35	37	27	16	57	6	10	51	44	56	33	51	44	38
1"	33.4	44	56	33	60	44	41	35	19	64	6	10	60	51	62	35	60	57	43
1 1/4"	42.2	51	62	35	67	57	44	44.5	21	70	7	14	72	60	75	43	67	64	46
1 1/2"	48.3	60	75	43	79	64	44	51	21	79	8	16	80	64	84	44	79	76	48
2"	60.3	64	84	45	86	76	48	63.5	22	88	9	17	94	83	102	52	86	92	51
2 1/2"	73.02	83	102	52	92	92	60	76	27	118	10	21	122	95	121	64	92	108	64
3"	89.0	95	121	64	108	108	65	89	29	121	10	25	140	106	146	79	108	127	68
4"	114.5	114	152	79	121	140	68	117.5	32	150	13	25	180	114	152	79	121	159	75

SOCKET WELD FITTING TO ANSI B-16.11

90° ELBOWS

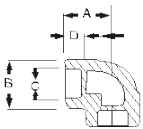

TEE

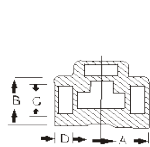

45° ELBOW

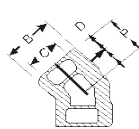

UNION

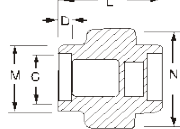

COUPLING

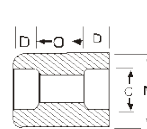

REDUCER

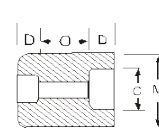

HALF COUPLING

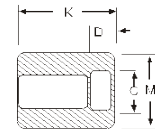

CAP

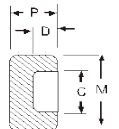

NOM BORE	PIPE O.D.	3000 L.B.S.						COMMON FACTORS						6000 L.B.S					
		A	B	K	J	L	M	N	P	Q	C min	D min	O min	O max	A	B	M	K	N
1/8"	10.3	22	18.5	26	16	40	17.3	32	17.5	10	10.7	10	5	8	22	22	20	25	46
1/4"	13.7	22	22	26	18	43	21.2	32	17.5	10	14.1	10	5	8	27	25	24	25	51
3/8"	17.2	25	25	26	19	48	25.4	36	19	10	17.6	10	3	9	27	28	28	26	60
1/2"	21.3	27	32	30	21	51	31	43	22	10	21.7	10	6	13	31	34	34	31	72
3/4"	25.7	34	38	36	24	57	37	50	25	13	27	13	6	13	37	42	41	35	80
1"	33.4	37	46	40	25	64	45.2	60	27	13	33.8	13	9	17	42	50	50	40	94
1 1/4"	42.2	42	56	40	29	70	55	70	30	13	42.6	13	9	17	47	59	58	41	100
1 1/2"	48.3	47	62	40	30	79	61.4	78	32	13	48.7	13	9	17	53	67	55	43	122
2"	60.3	56	75	52	37	89	75	95	38	13	61.2	16	15	23	59	84	83	55	
2 1/2"	73.02	60	92	52	48	114	91.3	125	38	16	73.8	16	14	24		102		56	
3"	89.00	76	110	52	51	127	108.8	140	44	16	89.8	16	14	24		121		58	
4"	114.50	88	137	58		150	136.9		48	19	115.5	19	14	24		152		64	

DIMENSIONS AND OTHERS SPECIFICATIONS AS PER CUSTOMERS REQUIREMENTS ARE AVAILABLE ON REQUEST

Screwed Unions (Dimensions in Millimeters)

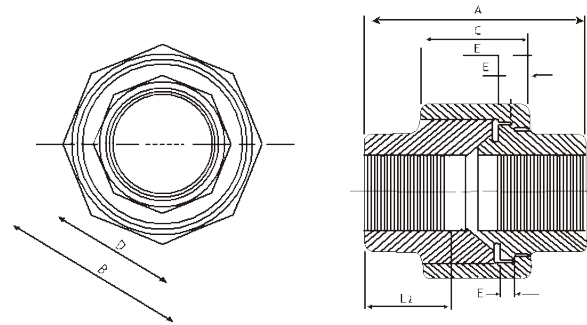

Pressure Class 3000

N,B	Dim.A (mm)	Dim.B (mm)	Dim.C (mm)	Dim.D (mm)	Dim.D (mm)
6	40	32	16	17	3.2
8	43	32	18	19	3.2
10	48	36	19	22	3.2
15	51	43	21	30	4.0
20	57	50	24	36	4.8
25	64	60	25	41	4.8
32	70	70	29	50	5.6
40	79	78	30	60	5.6
50	89	95	37	70	6.4
65	118	125	48	85	9.6
80	121	140	51	100	12.7

Socket Weld Unions (Dimensions in Millimeters)

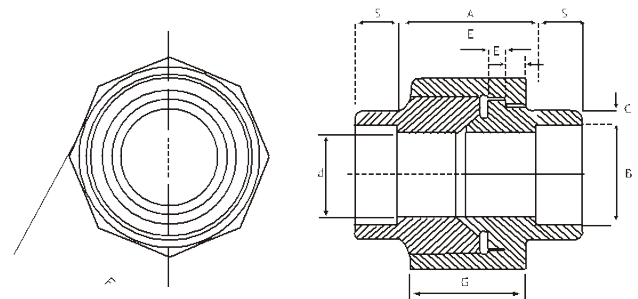

Pressure Class 3000

N,B	Dim.A (mm)	Dim.B (mm)	Dim.C (mm)	Dim.d (mm)	Dim.E (mm)	Dim.F (mm)	Dim.G (mm)	Dim.S (mm)
6	17	10.7	3.2	6.8	3.2	32	16	10
8	17	14.1	3.3	9.2	3.2	32	18	10
10	17	17.6	3.5	12.5	3.2	36	19	10
15	18	21.8	4.1	15.5	4.0	41	21	10
20	20	27.4	4.3	21.0	4.8	50	24	13
25	26	34.1	5.0	26.5	4.8	60	25	13
32	28	42.9	5.3	35.0	5.6	70	29	13
40	30	49.0	5.6	40.0	5.6	78	30	13
50	36	51.0	6.1	52.0	6.4	95	37	16
65	57	73.8	7.7	62.0	9.6	125	48	16
80	70	86.7	9.3	78.0	12.7	140	51	16

PIPE NIPPLES LENGTHS AND SIZES

Nominal Pipe Size, in														
1/8	1/4	3/8	1/2	3/4	1	1 1/4	1 1/2	2	2 1/2	3	3 1/2	4	5	6
Nominal Nipples Lengths, in														
3/4	7/8	1	1 1/8	1 3/8	1 1/2	1 5/8	1 3/4	2	2 1/2	2 5/8	2 3/4	2 7/8	3	3 1/8
1 1/2	1 1/2	1 1/2	1 1/2	1 1/2	1 1/2	1 1/2	1 1/2	1 1/2	1 1/2	1 1/2	1 1/2	1 1/2	1 1/2	1 1/2
2	2	2	2	2	2	2	2	2	2	2	2	2	2	2
2 1/2	2 1/2	2 1/2	2 1/2	2 1/2	2 1/2	2 1/2	2 1/2	2 1/2	2 1/2	2 1/2	2 1/2	2 1/2	2 1/2	2 1/2
3	3	3	3	3	3	3	3	3	3	3	3	3	3	3
3 1/2	3 1/2	3 1/2	3 1/2	3 1/2	3 1/2	3 1/2	3 1/2	3 1/2	3 1/2	3 1/2	3 1/2	3 1/2	3 1/2	3 1/2
4	4	4	4	4	4	4	4	4	4	4	4	4	4	4
	5	5	5	5	5	5	5	5	5	5	5	5	5	5
	6	6	6	6	6	6	6	6	6	6	6	6	6	6
		8	8	8	8	8	8	8	8	8	8	8	8	8
			10	10	10	10	10	10	10	10	10	10	10	10
			12	12	12	12	12	12	12	12	12	12	12	12

BS 3799



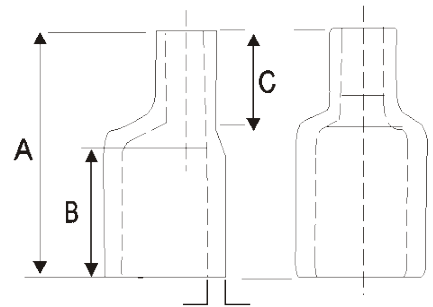
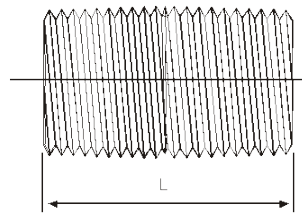
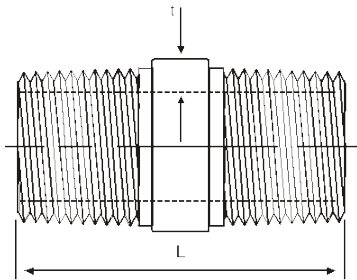



SWAGES

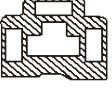

Nominal Size	Lengths in mm			Nominal Size	Lengths in mm		
mm	A	B	C	mm	A	B	C
10X8	76	48	16	50X15	165	108	29
15X8	89	56	19	50X20	165	108	29
15X10	89	56	19	50X25	165	108	23
20X10	95	57	22	50X32	165	108	29
20X15	95	57	22	50X40	165	108	29
25X15	102	64	22	65X40	178	114	32
25X20	102	64	22	65X50	178	114	32
32X15	102	64	22	80X40	203	133	41
32X20	102	64	22	80X50	203	133	41
32X25	102	64	22	80X65	203	133	41
40X15	114	70	25	100X40	229	140	48
40X20	114	70	25	100X50	229	140	48
40X25	114	70	25	100X65	229	140	48
40X32	114	70	25	100X50	229	140	48

Wall thickness "t" is as required by pressure rating/pipe schedule

SW FORGED FITTINGS ANSI B16.11-BS3799 3-6-9111LBS

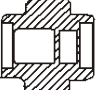
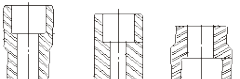
Type	Rating	1/4"	3/8"	1/2"	3/4"	1"	1 1/4"	1 1/2"	2"	2 1/2"	3"	4"
90° ELBOW 	3000	0.082	0.115	0.235	0.290	0.480	0.750	0.950	1.65	2.50	4.30	9.70
	6000	0.165	0.300	0.430	0.660	1.14	1.60	2.70	2.95	3.75	7.50	13.00
	9000			0.850	1.500	2.25	3.35	3.90	4.25			
45° ELBOW 	3000	0.078	0.100	0.192	0.250	0.380	0.560	0.830	1.15	2.05	3.40	9.00
	6000	0.120	0.240	0.300	0.530	0.860	1.07	1.90	2.35	3.00	6.00	10.30
	9000			0.600	1.18	1.55	2.40	3.45	3.55			
TEES 	3000	0.118	0.190	0.310	0.400	0.580	0.910	1.25	2.10	3.15	5.25	13.50
	6000	0.210	0.400	0.555	0.910	1.41	1.75	3.56	4.10	6.25	10.30	17.00
	9000			1.04	1.85	2.32	3.50	4.55	5.00			
CROSSES 	3000	0.135	0.205	0.340	0.470	0.800	1.25	1.50	2.23	3.95	6.50	16.00
	6000	0.260	0.495	0.670	1.06	1.79	2.15	4.45	5.40	7.75	12.80	21.00
	9000			1.29	2.25	2.85	4.30	5.6	5.90			
COUPLING 	3000	0.050	0.065	0.105	0.152	0.260	0.370	0.420	0.770	1.10	1.40	2.35
	6000	0.070	0.095	0.148	0.335	0.370	0.490	0.680	1.24	1.81	2.80	3.50
	9000			0.230	0.410	0.640	0.800	0.890	1.63			
HALF COUPLINGS 	3000	0.058	0.085	0.180	0.205	0.320	0.410	0.560	0.960	1.50	2.00	3.40
	6000	0.075	0.110	0.205	0.300	0.470	0.600	1.05	1.60	2.30	2.65	5.00
	9000			0.260	0.410	0.650	0.800	1.25	2.10			
CAP 	3000	0.035	0.60	0.135	0.175	0.295	0.510	0.650	0.920	1.40	2.50	3.50
	6000	0.075	0.110	0.180	0.210	0.460	0.700	0.885	1.20	2.00	3.25	5.50
	9000			0.235	0.280	0.600	0.880	1.10	1.60			
UNION 	3000	0.180	0.225	0.385	0.520	0.730	1.20	1.56	2.30	5.00	7.15	15.25
	6000	0.350	0.550	1.15	1.57	2.10	2.65	3.60	5.50	9.50	19.00	25.00
	9000			1.25	1.70	2.35	2.95	4.75	6.50			
M/F Reducing Insert 	3000	0.040	0.050	0.100	0.120	0.160	0.350	0.450	0.700			
	6000			0.250	0.300	0.350	0.500	0.650	1.00			
	9000			0.350	0.400	0.480	0.650	0.800	1.25			



APPROXIMATE WEIGHT 3000# SCR D

NOMINAL PIPE SIZE	in mm	1/8	1/4	3/8	1/2	3/4	1	1 1/4	1 1/2	2	2 1/2	3	4
		3.2	6.4	9.5	12.7	19.0	25.4	31.7	38.1	50.8	63.5	76.2	101.6
90° ELBOW	lbs.	0.25	0.37	0.62	1.31	1.37	2.25	2.75	3.50	5.43	10.68	14.43	30.37
	kgs.	0.11	0.16	0.28	0.60	0.62	1.02	1.24	1.6	2.46	4.84	6.54	13.77
45° ELBOW	lbs.	0.25	0.25	0.50	0.75	1.18	1.87	2.12	3.00	4.25	7.37	10.50	19.06
	kgs.	0.11	0.11	0.22	0.34	0.53	0.84	0.96	1.36	1.92	3.34	4.76	8.64
TEE	lbs.	0.25	0.37	0.81	1.18	1.87	2.50	3.12	5.00	6.75	13.12	20.37	39.50
	kgs.	0.11	0.16	0.36	0.53	0.84	1.13	1.41	2.26	3.05	5.95	9.24	17.91
STREET ELBOW	lbs.	0.25	0.25	0.37	0.50	0.87	1.43	2.25	3.00	5.18	-	-	-
	kgs.	0.11	0.11	0.16	0.22	0.39	0.64	1.02	1.36	2.34	-	-	-
LATERAL	lbs.	--	0.62	1.31	1.75	2.75	4.62	5.50	10.81	-	-	-	-
	kgs.	--	0.28	0.59	0.79	1.24	2.10	2.50	4.90	-	-	-	-
CROSS	lbs.	0.43	0.37	1.00	1.50	2.50	3.56	4.12	6.50	8.12	16.75	19.75	32.00
	kgs.	0.19	0.16	0.45	0.68	1.13	1.61	1.87	2.94	3.68	7.60	8.95	14.51
UNION	lbs.	0.31	0.31	0.43	0.75	0.93	1.43	2.12	2.75	4.43	12.12	17.62	35.20
	kgs.	0.14	0.14	0.19	0.34	0.42	0.64	0.96	1.24	2.00	5.50	8.00	16.0

APPROXIMATE WEIGHT 6000# SCR D

NOMINAL PIPE SIZE	in mm	1/8	1/4	3/8	1/2	3/4	1	1 1/4	1 1/2	2	2 1/2	3	4
		3.2	6.4	9.5	12.7	19.0	25.4	31.7	38.1	50.8	63.5	76.2	101.6
90° ELBOW	lbs.	0.25	0.62	1.06	1.62	2.62	3.5	6.75	7.5	13.43	20.87	34.56	38
	kgs.	0.11	0.28	0.5	0.73	1.2	1.6	3.06	3.4	6.1	9.46	15.67	17.23
45° ELBOW	lbs.	0.25	0.56	0.5	1.43	2.18	2.68	4.68	5.75	9.5	15	30.56	29
	kgs.	0.11	0.25	0.22	0.64	1	1.21	2.12	2.6	4.31	6.8	13.86	13.15
TEE	lbs.	0.5	1	1.37	2.12	3.62	4.52	7.62	9.62	18.87	28.06	45.62	50
	kgs.	0.22	0.45	0.62	0.96	1.64	2.1	3.45	4.36	8.56	12.72	20.7	22.68
STREET ELBOW	lbs.	--	0.37	0.43	1	1.62	2.5	3.68	5.43	--	--	--	--
	kgs.	--	0.16	0.19	0.45	0.73	1.13	1.67	3	--	--	--	--
LATERAL	lbs.	--	--	2.37	3.25	5.43	7.18	12.31	--	--	--	--	--
	kgs.	--	--	1.07	1.47	2.46	3.25	5.6	--	--	--	--	--
CROSS	lbs.	0.56	1.18	1.5	2.75	4.31	5.52	10.75	11.5	22.18	27.5	54	43.5
	kgs.	0.25	0.53	0.68	1.24	2	2.54	4.87	5.21	10.06	12.47	24.5	19.73